

# RISO MG-11

## OWNERS GUIDE

### INDEX

Set contents .....	2	4. Printing .....	10
Parts Description .....	3	Colorful stamping .....	13
Operational procedure .....	3	How to use the MG Stamp .....	14
1. Preparing original artwork .....	4	Imaging masters for PRINT GOCCO B6 .....	15
2. Imaging the MG Master .....	6	Applications .....	15
3. Applying Ink .....	8		

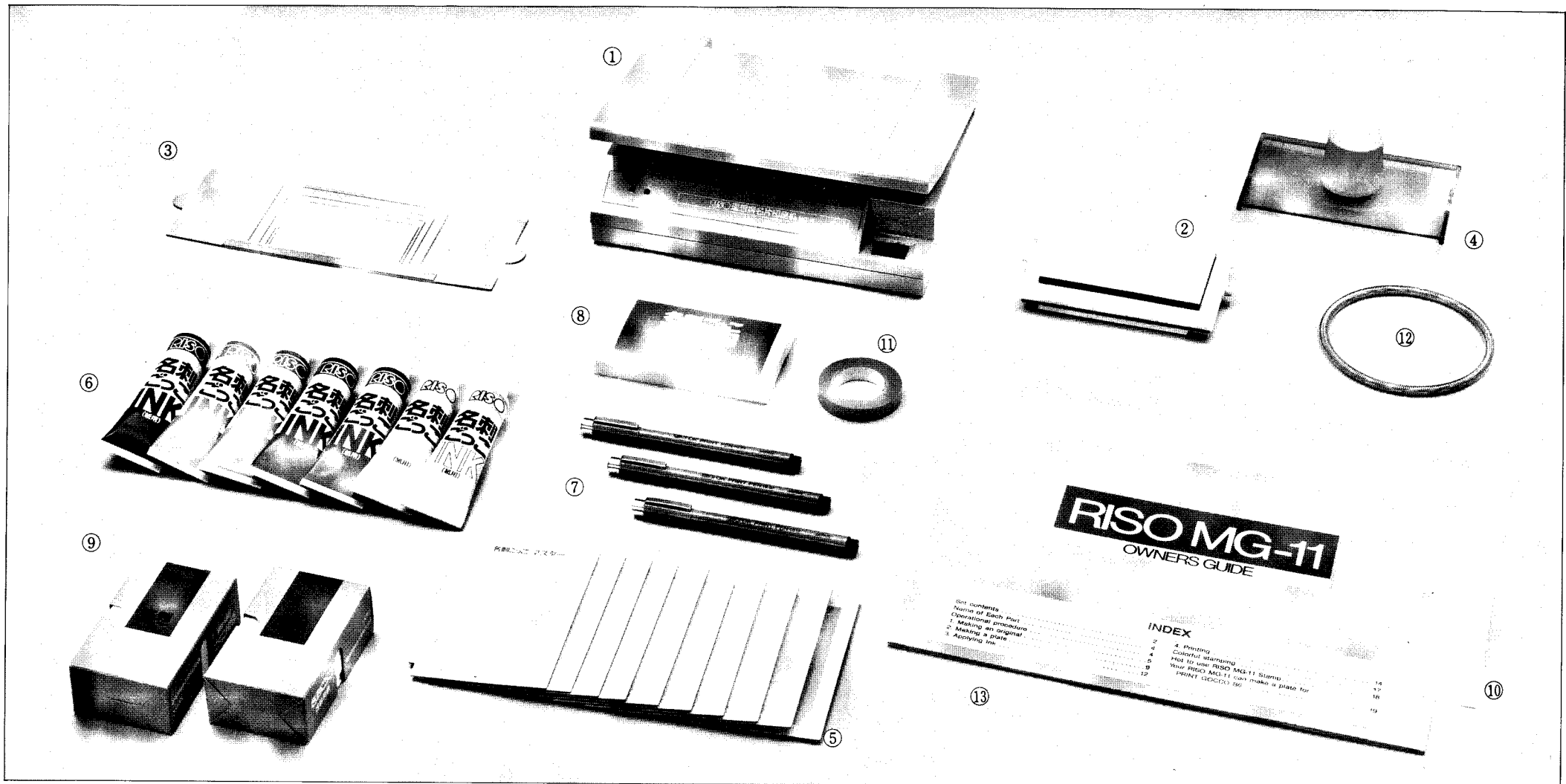

Congratulations on the purchase of your RISO MG-11. Your RISO MG-11 is a high performance multi-colour printer suitable for printing a wide variety of items for both business and personal use. Some of the applications include business cards, index cards, greeting cards, personalized stationery, letterheads, brochure overprinting, carton marking and many many more. We are sure you will enjoy the many applications to which you will put your RISO MG-11 and are indeed assured that it will serve many hours of printing those small quantity requirements. Before using your RISO MG-11, be sure to read this manual. This manual is designed to provide you with the guidelines for the use of your RISO MG-11 and contains a section of various techniques in all aspects of preparing and printing your work.

### SET CONTENTS

Please confirm the following components contained in your RISO MG-11. Any shortages or damaged components should be reported to the store that sold your RISO MG-11.

① RISO MG-11 (main unit)	1 unit
② Pad Table	1 unit
③ Printing Frame	1 pc.
④ MG Stamp	1 pc.
⑤ MG Masters	10 sheets
⑥ MG Ink (black, blue, red, yellow, brown, green white)	7 × 40cc tubes
⑦ RISO Pen Fine—0.1mm, 0.3mm, 0.5mm	1 pc. each
⑧ Stick Paper	100 sheets
⑨ Business Card (white: 100 sheets; 4 colors: 25 sheets each)	2 packs (200 sheets in all)
⑩ Drawing Paper	1 sheet
⑪ Both-Side Adhesive Tape	1 roll
⑫ Card Holder	1 pc.
⑬ Owners Guide	1 copy

### Helpful Hints

- ① Use your RISO MG-11 at room temperature of 15°C to 30°C.
- ② Moisture and dust have a detrimental effect on the MG Masters. Remove the Masters from the protective plastic bag just before use, as required.
- ③ Secure the caps of ink tubes after use. Store the tubes out of the reach of children. Never store the tubes at temperatures below zero or above 40°C.

# PARTS DESCRIPTION

## RISO MG-11 main unit

## MG Stamp

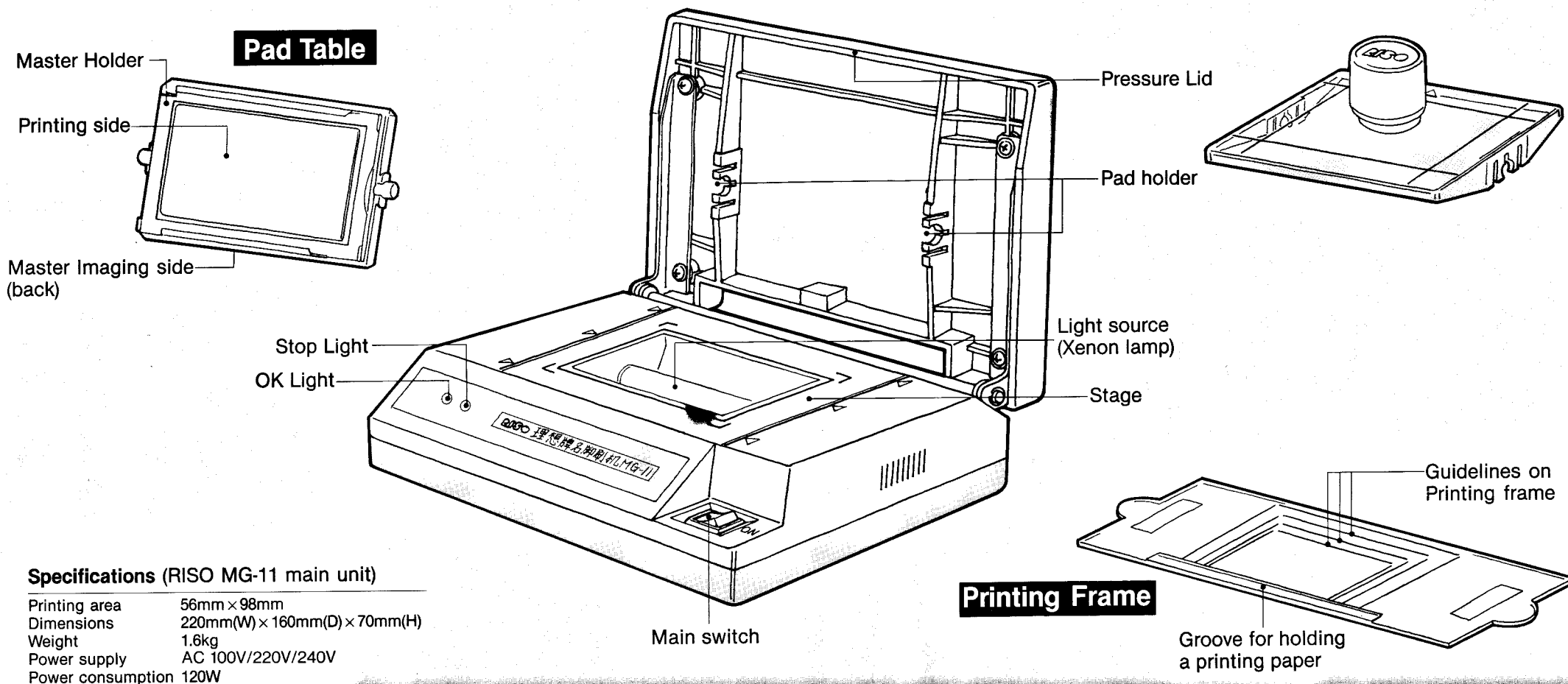

### Specifications (RISO MG-11 main unit)

Printing area	56mm × 98mm
Dimensions	220mm(W) × 160mm(D) × 70mm(H)
Weight	1.6kg
Power supply	AC 100V/220V/240V
Power consumption	120W

## OPERATIONAL PROCEDURE

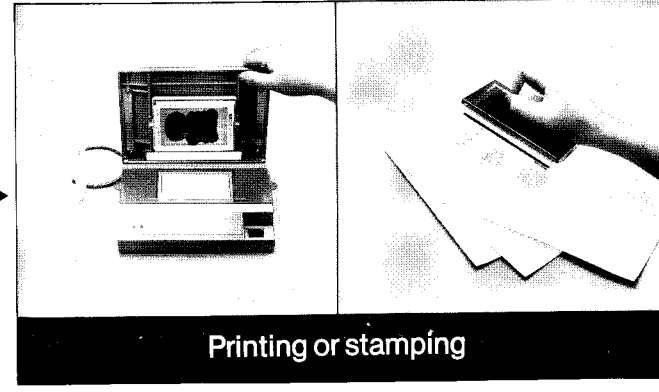
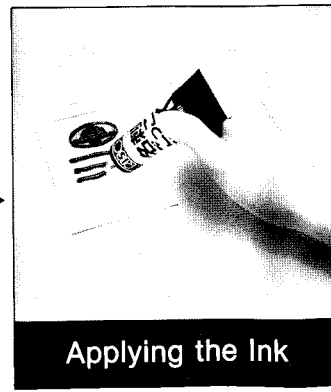
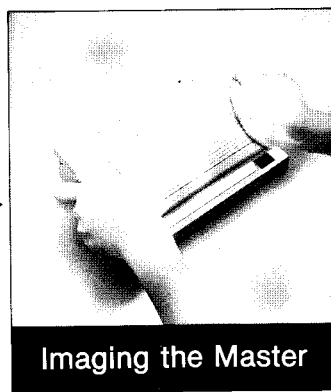
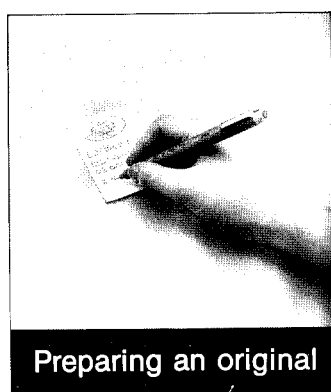

# 1. PREPARING ORIGINAL ARTWORK

① Use a piece of paper, and write with the RISO Pen.

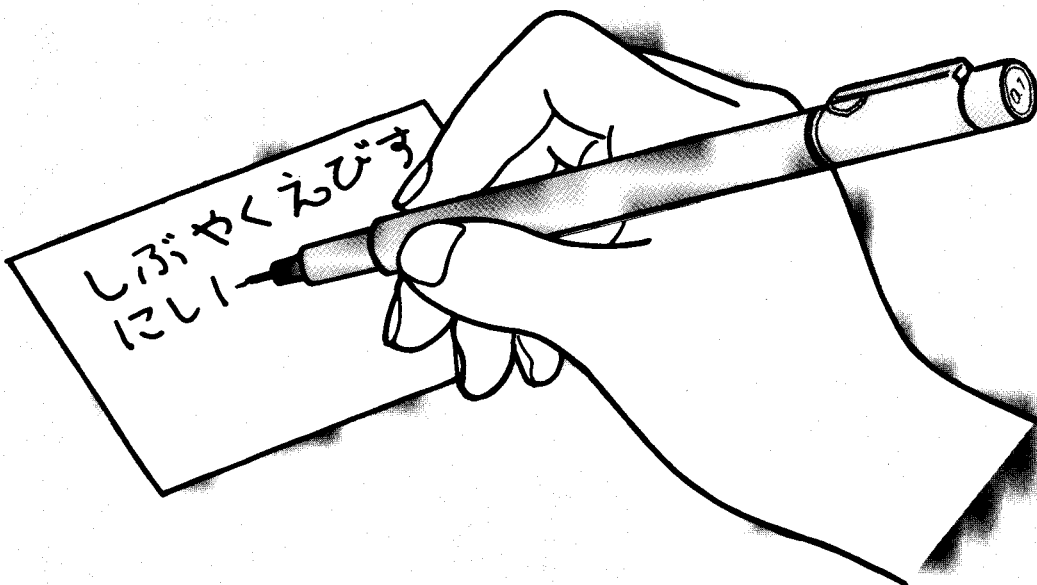

② Choose and cut out a drawing from the design book. Write other details such as your name, address and telephone number etc. with the RISO Pen.

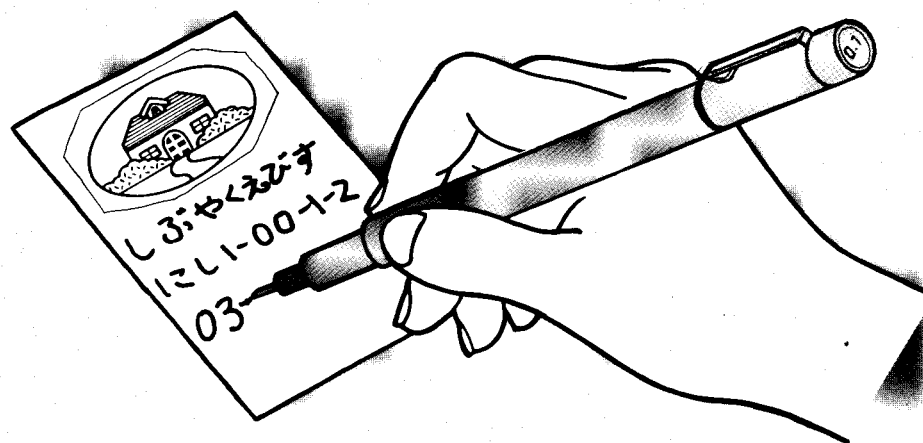
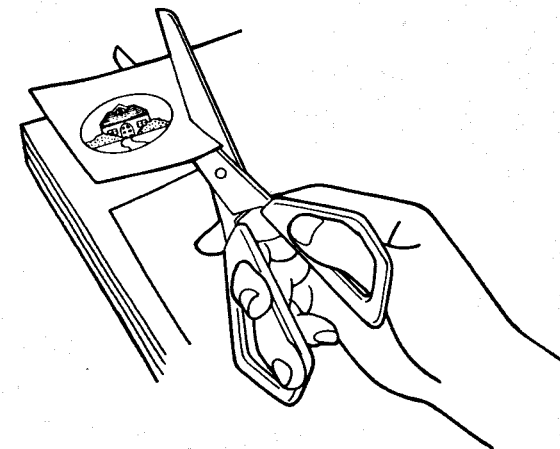

## Writing instruments for use RISO MG-11

RISO MG-11 utilizes a thermal imaging system, therefore, the Master imaging is possible only with carbon-based original artwork. Be sure to use the RISO Pen provided with your RISO MG-11 or other suitable artwork pen.

**Note 1:** When writing or drawing originals, do so on a firm surface to prevent paper indentation which will result in poor quality artwork.

**Note 2:** After writing or drawing the artwork, make sure that it is thoroughly dry before imaging the Master. If the ink still contains moisture, a satisfactory Master cannot be made. Artwork can be dried with a hair dryer to achieve a satisfactory result.

**Note 3:** Standard ball-point pens, felt-tip pens, fountain pens and similar writing instruments cannot be used for preparing the original artwork as their inks do not contain carbon, even though they print black. Use one of the following writing instruments available from your Riso Dealer/Retailer.

## Writing instruments for use RISO MG-11 (available at nearby stationery or department stores)

	RISO products	Other articles on the market
Fine script	•RISO Pen Fine <0.1> <0.3> <0.5>	•Desk Pen (for dipping in such ink as drafting ink, ink for securities certificates)
Medium script	•RISO Pen Medium	
Bold script	•RISO Pen Bold •RISO Pen Brush	•Writing brush (for use with ready made Indian ink, drafting ink, ink for securities certificates, ink prepared with an inkstone)
Others		•Black crayon, Pencil

## Limit original size to within 56mm×98mm

If artwork exceeds these dimensions, the edges may not be printed properly. Use the drawing Paper or printing paper provided in the set, or non-glossy (high or medium quality) paper.

•When making draft copies of your artwork, use a red pencil with a light touch. The red lines will not reproduce as they do not contain carbon and need not be removed from the artwork.

# TO MAKE YOURS MORE THAN A MERE VISITING CARD

## Ex. 1: A message card Cut and apply instant lettering available in stores.

- Before imaging, make a copy using a liquid/dry type photocopy machine.

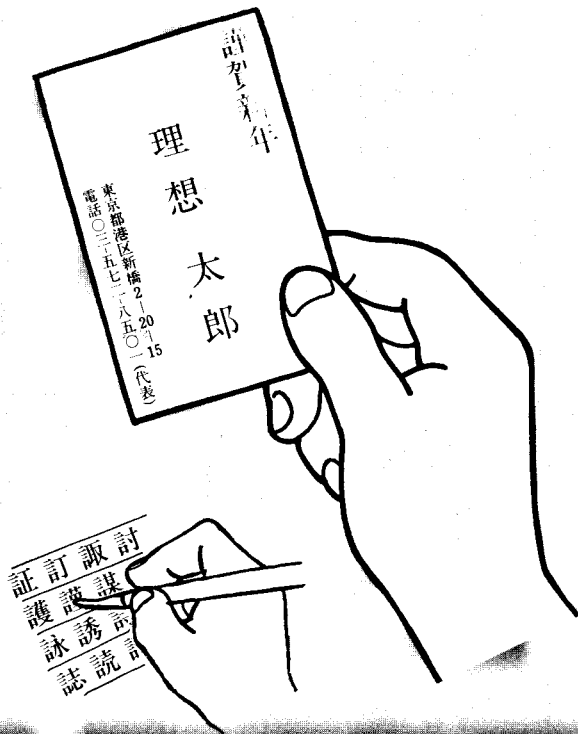

## Ex. 2: A campaign card with a symbol or a slogan...

- If the symbol or slogan is clipped out of a color print or glossy paper, make a copy beforehand using a liquid/dry type photocopy machine.

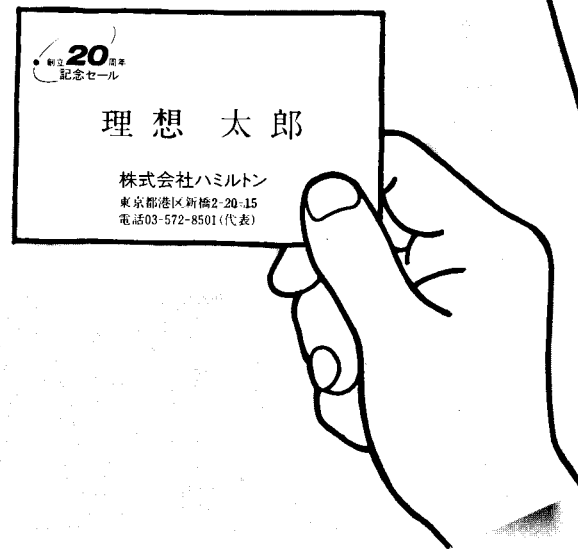

- Try using this technique to make your cards more impressive.

## Ex. 3: Print your photograph along with the message. This idea will make your prints look much more impressive.



- When using a stick glue...  
Apply the glue to 1 or 2 spots on the back of the original.  
Be careful not to place the glue directly behind lettering or illustrations.
- \* Liquid glue is not recommended as it moistens the original and does not allow for perfect imaging.

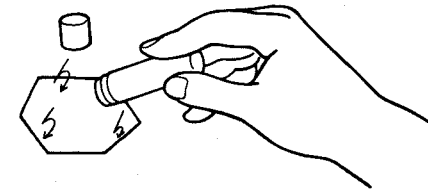

- When using Scotch tape...  
Place one or two pieces on the sides of the artwork. Be careful not to cover lettering or drawing as the Master must be in contact directly with the artwork to image.

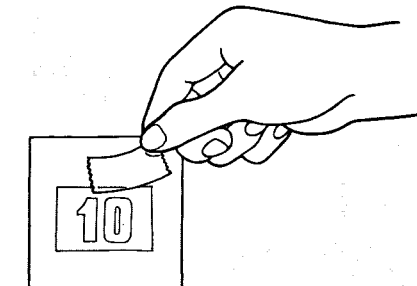

### Photo-copies

There are many types of artwork that may not be used directly in your MG-11. These include artwork made up of ball-point pens, felt marker and most writing instruments. Photos, type-setting, gravure printing, colour printing, instant lettering, dot screen tones, glossy papers, etc. To convert these to artwork suitable for use in your RISO MG-11, simply photo-copy the artwork and use the photo-copy as the original. Photo-copiers produce carbon based artwork.

The Blue Print Filter (optional extra) is for use with photo-copied originals. Most photo-copy machines leave a residue of toner over the entire sheet of paper. You cannot see these but they show up in your printed copies as tiny specks printed on your page. It is recommended that you use the Blue Print Filter at all times when such photocopies are used as originals.

\*Liquid/dry type photo-copy machines and a few dry photo-copy machines are suitable for RISO MG-11.

When using such machines, you do not need the Blue Print Filter.

### An original from clippings

Cutouts from newspapers and magazines containing carbon may be used directly as original artwork. Originals printed on glossy papers cannot be used directly for original artwork. Check to ensure that the magazine has not been gravure printed as this type of printing is not suitable for original artwork. Photocopies of these types of artwork are suitable.

Caution: The Copyright Law prohibits the reproduction of articles and drawings from any publications without the written permission of the publishers and/or author.

As these laws vary in different areas, it is advisable to check the copyright laws relating to the particular piece of work that you wish to reproduce. Many publications are made for the express purpose of reproduction and contains copyright free drawings. You can obtain these art books from most of your local Dealers/Retailers.

### Photographs as original artwork

A photograph is not suitable for use directly as original artwork. In order to use the photograph it is necessary to photocopy it using an OK Photo Screen 65. The resulting photocopy may be used as the original artwork.

## 2. IMAGING THE MG MASTER

- 1 Mount the pad into the pad holder with the imaging processing side facing outwards.

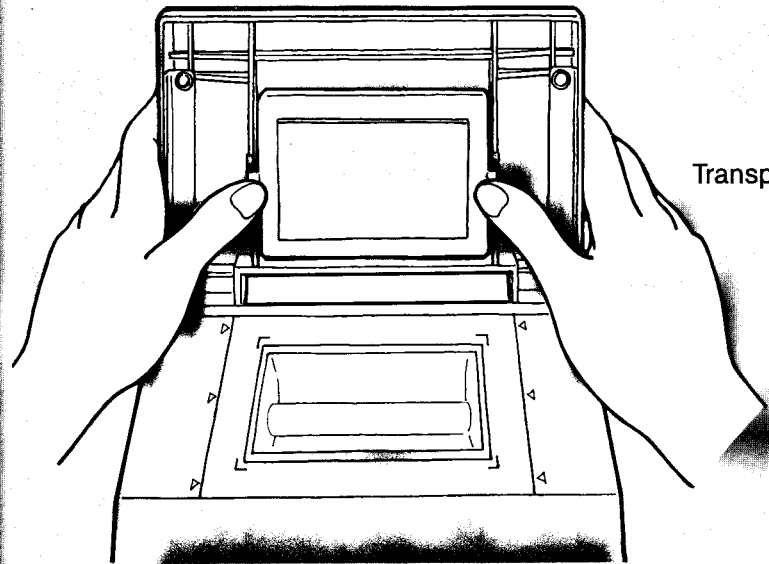

- 2 Put the Master on the stage with the plastic transparent sheet facing down. Make sure to set the Master to the alignment markings on the stage.

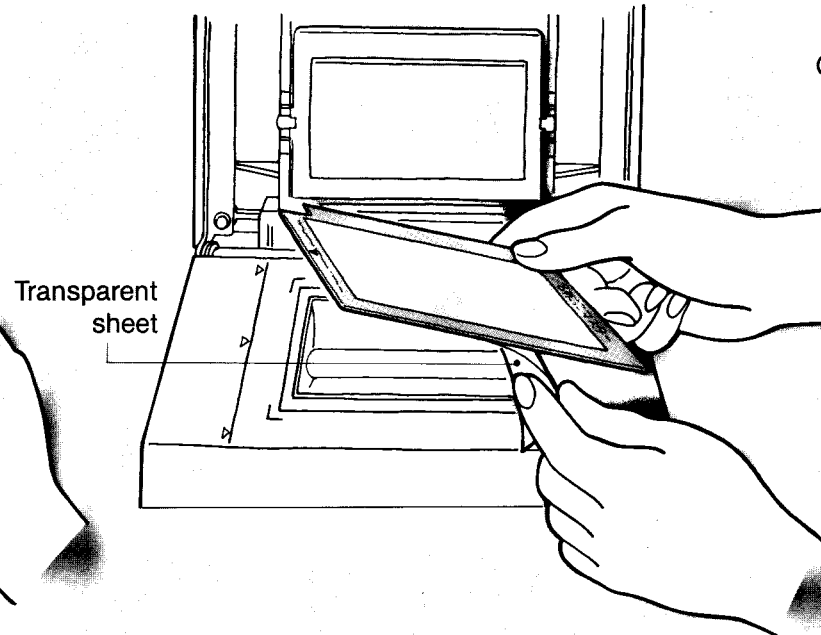

- 3 Place the original face down on the Master.

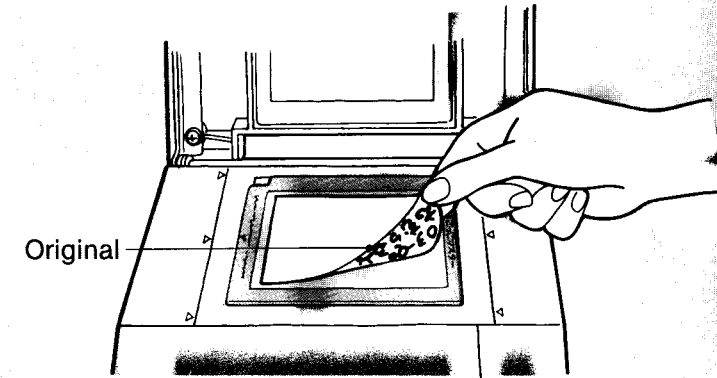

- 4 Position the original in the center of the Master.

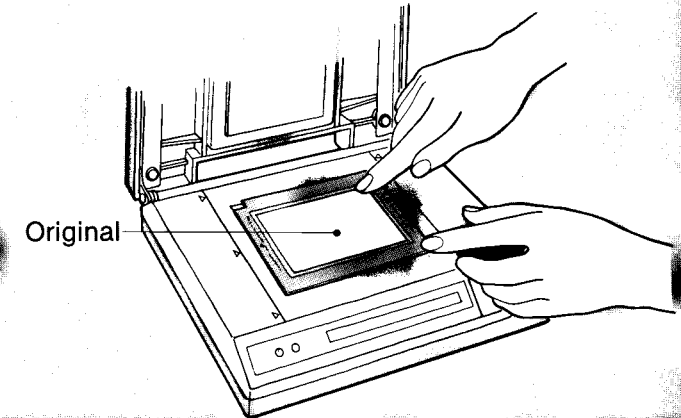

Before imaging the Master, wait until the original is dry.

If wet, a satisfactory plate cannot be produced. Dry it with a hair dryer, etc.

If the Master does not image properly

- 1 Does the lettering or drawing of an original contain carbon? Start again with the writing instruments recommended earlier, or by making a copy of the original with a liquid/dry type photocopy machine. When written in Indian ink, the original must be dried before imaging (see pages 4 and 5).
- 2 Is the setting of the RISO MG-11 incorrect? Is the original out of alignment? (Correctly follow the steps illustrated above.)

If the stop light is flashing

- 1 Is the RISO MG-11 overheated? 10 to 20 consecutive flashes may overheat your machine. Turn off the main switch, and wait 15 to 20 minutes for the machine to cool. You may then proceed with your work.
- 2 Is the room temperature too low? The RISO MG-11 does not work when the room temperature is below 10 degrees centigrade (50°F). Warm up the room before use.

Basic principles of flash imaging

Direct sunlight produces intense heat when focused by a lens, and burns the black part on a sheet of paper.

This is the principle behind plate-making with the RISO MG-11. The infrared rays from the xenon lamp located at the bottom of the stage turn into heat when radiated upon the black letters or black lines (carbon) of the original, making holes in the Master that correspond exactly to the original. This is why the writing or drawing ink must contain carbon.

- 5 Turn on the main switch. After approximately 10 seconds, the OK light will glow to indicate the machine is ready for imaging.**

(The charging time of the machine will vary slightly according to the local power supply.)

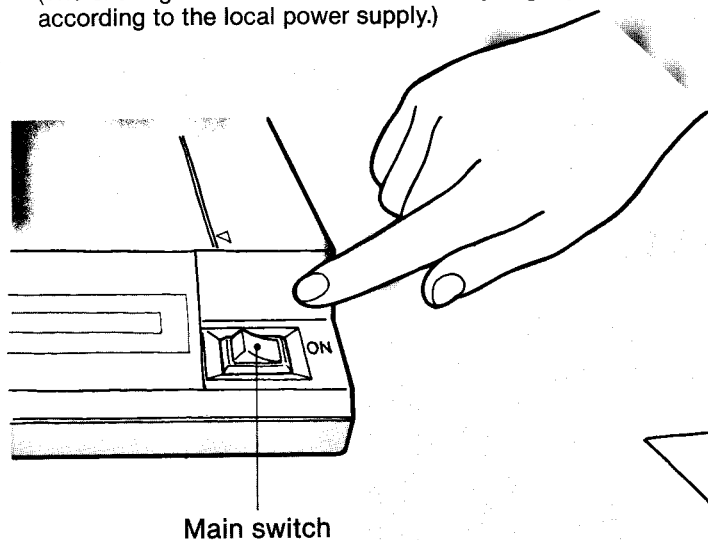

- 6 Press down evenly with both hands on the pressure lid until the unit flashes. Your Master is now imaged.**

- Use both hands to press both sides of the pressure lid and apply pressure evenly.
- After the plate is imaged, make sure the main switch is turned off.

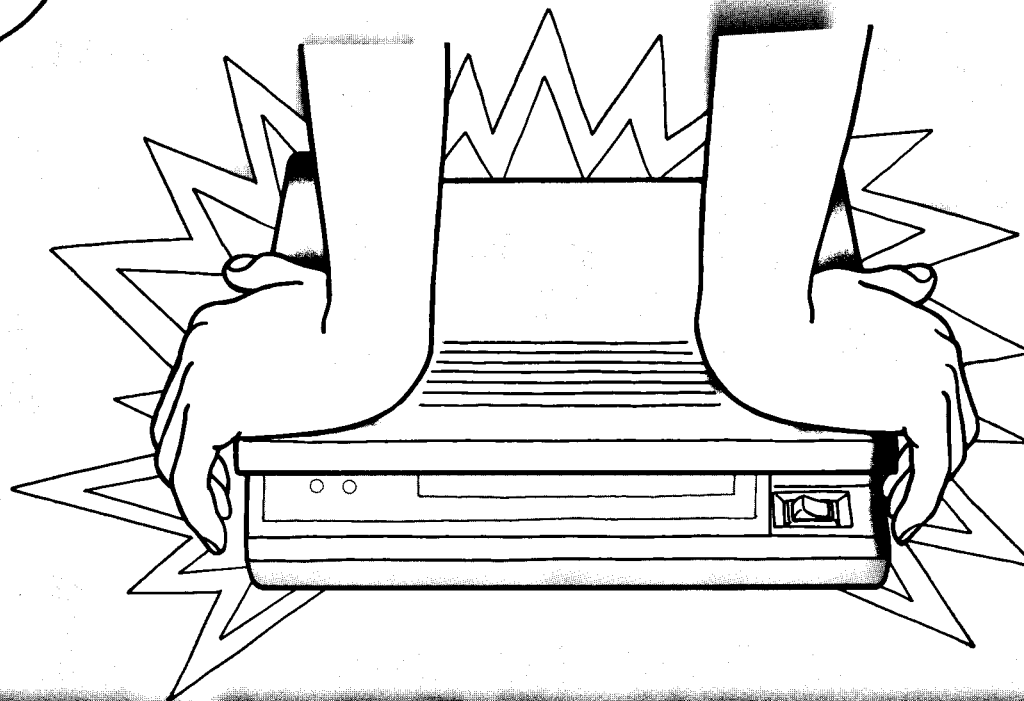

- If the pressure lid is not pressed evenly or on one side, the imaging lamp may not flash.

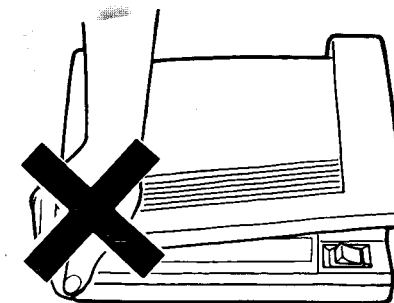

If the Imaging lamp (xenon lamp) does not flash:

Symptom	Measure
OK light is ON.	<ul style="list-style-type: none"> <li>• Try the steps illustrated above once again.</li> </ul>
OK light is OFF.	<ul style="list-style-type: none"> <li>• Is the power cord disconnected Make sure the plug is properly inserted in the wall socket.</li> <li>• Is the main switch in the OFF position? Turn it on.</li> </ul>
STOP light is ON.	<ul style="list-style-type: none"> <li>• If you have flashed the lamp 10 to 20 times continuously, your machine may be overheated. Wait 15 to 20 minutes or until it is cool.</li> <li>• Is the room temperature below 10°C (50°F)? The RISO MG-11 may not work when the room temperature is below 10°C. Warm up the room before use.</li> </ul>

• If your machine still does not work after you have tried everything, then take it to your RISO MG-11 dealer for repair.

• Warning-high tension:

The machine is equipped with high tension sections which are very dangerous to touch. Never open the machine. For repair, employ a service man.

# 3. APPLYING INK

① Remove the original from the Master.

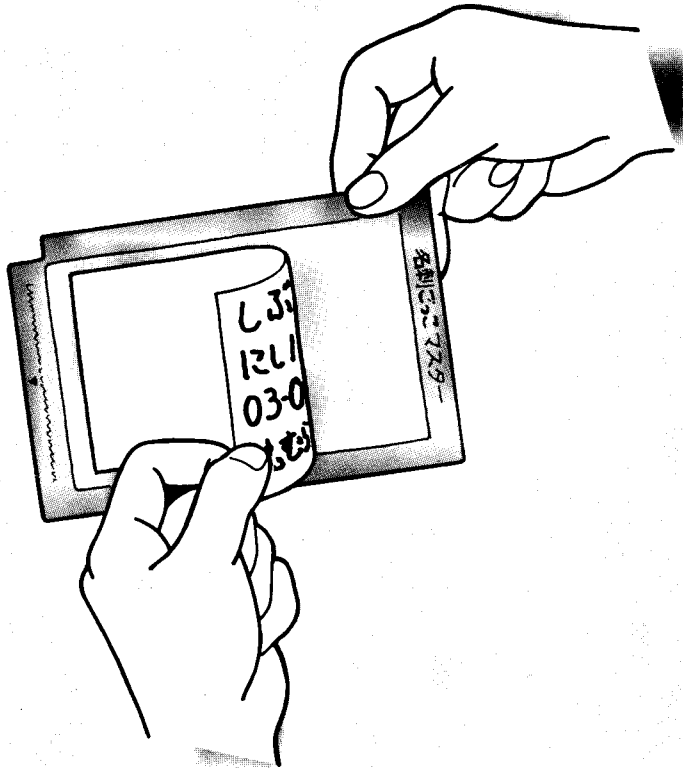

② Fold back the transparent cover sheet from the Master.

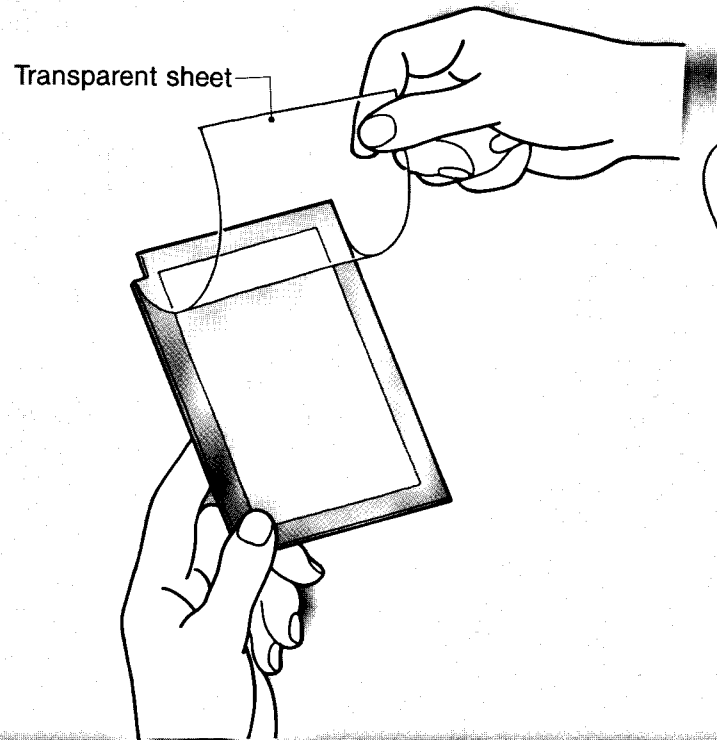

③ Spread ink generously over the Master covering the imaged pattern areas.

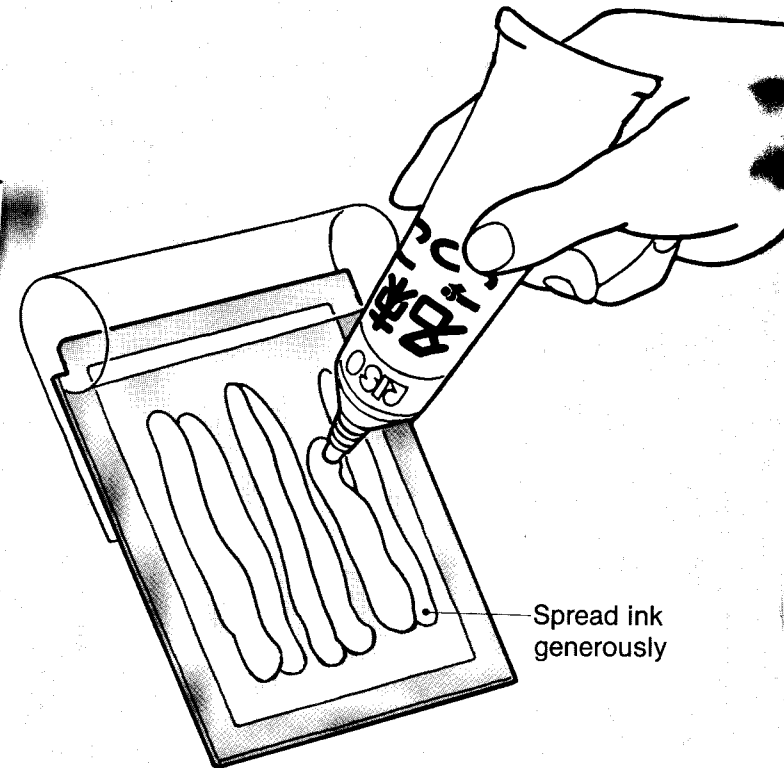

## Spread ink generously.

Press the ink tube to spread ink generously over the Master like squeezing a tube of tooth paste. You should apply a coat of ink approximately 3mm in thickness. This will prevent defaced or hazy prints, and will also ensure a print run of about 70 to 80 copies without the necessity to re-inking.

## Spreading the ink where the colors meet.

If the printing areas are reasonably separated, there is no need to worry if inks of different colours are placed close together as they will not mix. Where printing areas of different colours are very close together, place the ink carefully and evenly in the area where they meet. Make sure that you 'butt' the two colours as this will prevent ink flow from one area to the other.

## For fine closely drawn artwork

Squeeze some ink onto a palette, and then apply the ink to the Master by using a match, palette knife or other similar instrument. Use a cone or funnel from which the ink may be applied. Place the appropriate amount of ink into the cone and then squeeze the ink out in similar fashion to cake decorating. Ink cones are available from your local Dealer/Retailer. Make your own Ink Cone from a sheet of plastic film. This is a simple procedure as follows:

- ① Shape a flat piece of plastic film into a cone. Seal up the edge with Scotch tape.
- ② Cut the point of the cone to provide the required thickness.
- ③ Spread the ink by squeezing the tube. Ink which remains in an ink cone may be stored for about a month if it is sealed properly at the nozzle and is placed in a sealed plastic bag.

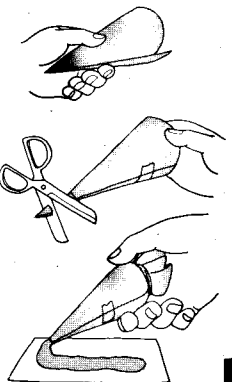



**4** Replace the transparent cover sheet on top of the ink.

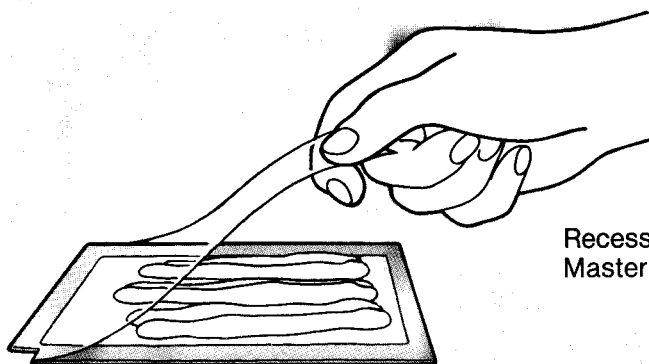

**5** Remove the pad table from the pad holder and slide the Master into the frame of the Master holder.  
 •Make sure that the corners are correctly aligned.

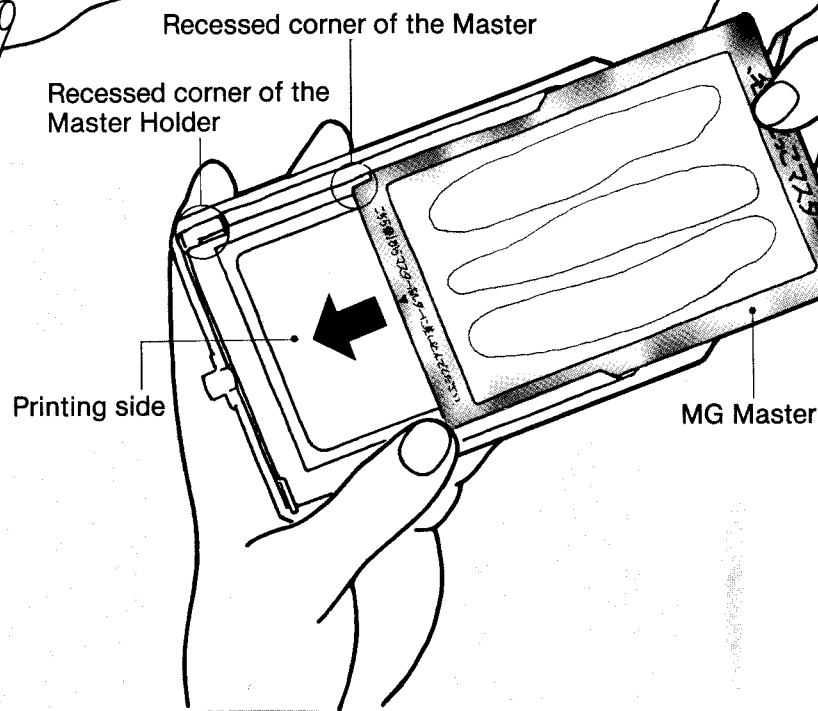

**6** Insert the Pad Table in the pad holder with the Master facing toward the front of the unit.

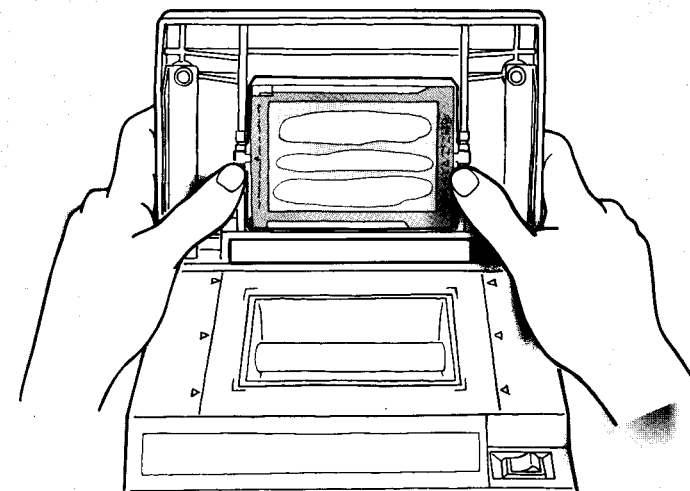

**Separating colors clearly.**

The inks for use in the RISO MG-11 do not mix with ordinary printing pressure. However the inks will flow from high to low spots. To prevent this, Ink Blocking (optional) strips positioned on the Master will confine the ink to designated areas.

**1** Cut the Ink Blocking sheet into this strips, remove the protective cover from the adhesive side.

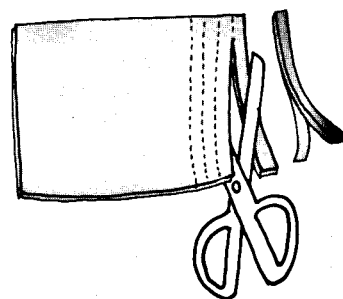

**2** Apply the strips to the Master in the required places. Apply the ink and print your copies.

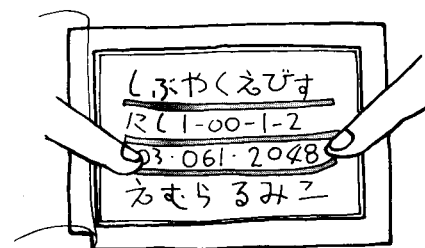

•Be careful not to smear your hands and clothing with ink.  
 To clean ink from your hands use a small amount of OK Cleaner. Rub onto your hands and then wash in water.  
 To clean ink from clothing, wash immediately in luke warm water with a liquid detergent. If this is not effective take the garment to a professional dry cleaner.

# 4. PRINTING

## ① Apply a stick paper to the stage of the main unit.

- Make sure that the stick edge is at the front of the stage and is placed precisely to the corners on the stage.

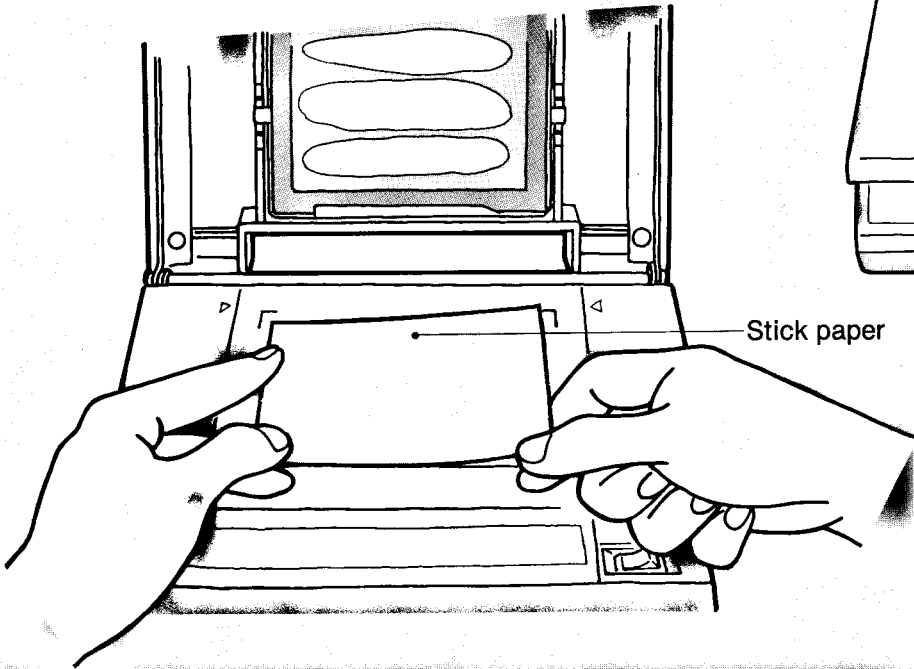

## ② Press down on the pressure lid to produce a proof copy. Do not remove the printed proof copy as this is required for your printing guide.

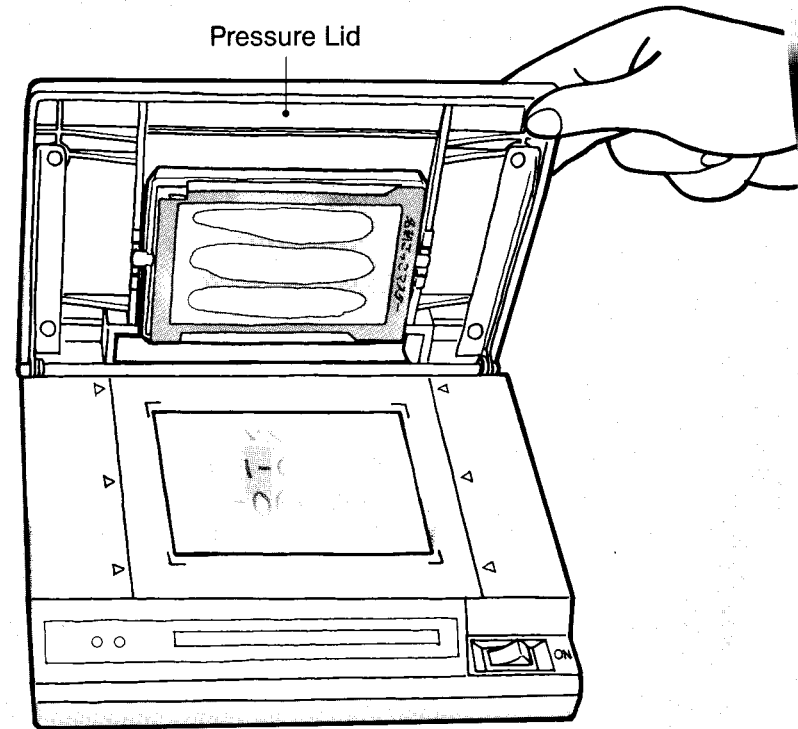
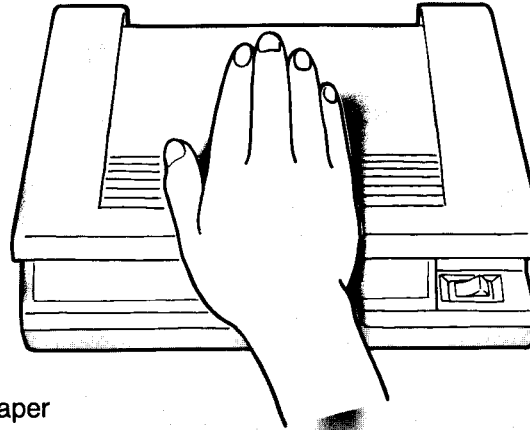

### Printing Paper

In addition to the Printing Paper provided in the kit, Japanese paper, bond paper, flock paper, wallpaper, etc. of various colors and designs can be used for unique printing. Such paper is available at stores that specialize in stationery and artwork. It is simple and effective to print an illustration or symbol in color on your calling cards.

	SIZE
Bussiness Card No. 3	85mm × 49mm
Bussiness Card No. 4	91mm × 55mm
Bussiness Card No. 5	100mm × 61mm
Bussiness Card No. 6	116mm × 70mm

### Re-inking

If the printed results become light and indistinct, the most probable cause is that the ink has run out. Apply more ink to the Master.

- Remove the Master from the Pad Table
  - Carefully fold back the transparent cover sheet.
  - Apply more ink to the Master in the required spots.
  - Replace the transparent cover sheet over the ink.
  - Re-insert the Master and resume printing.
- Clean by rubbing with a sheet of paper rolled into a scoop. This will work well to remove stains.

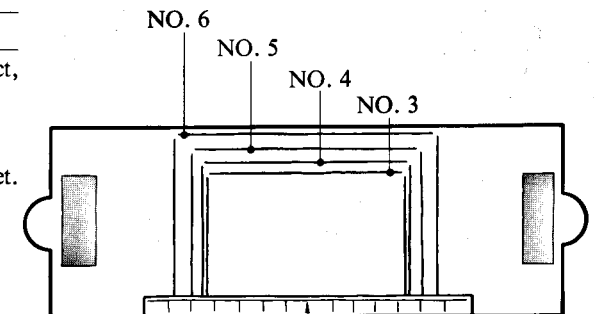

**③ Apply both-side adhesive tape to the opaque marked sections of both left and right sides of the back of the printing frame as illustrated below.**

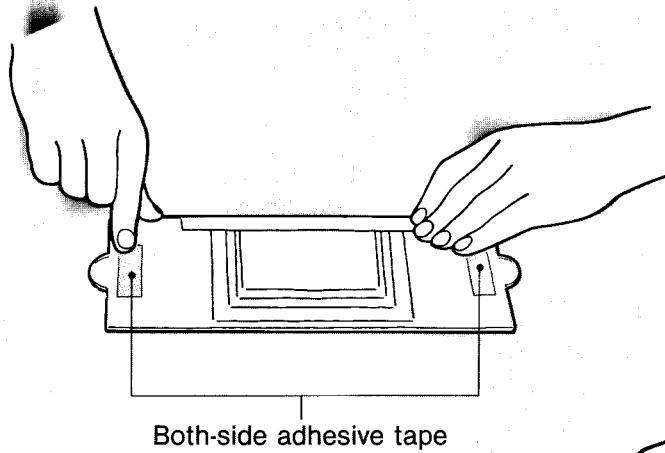

Both-side adhesive tape

**④ Fasten the printing frame to the stage.**

- Check the printing position by aligning the proof copy, with the guidelines on the Printing Frame.

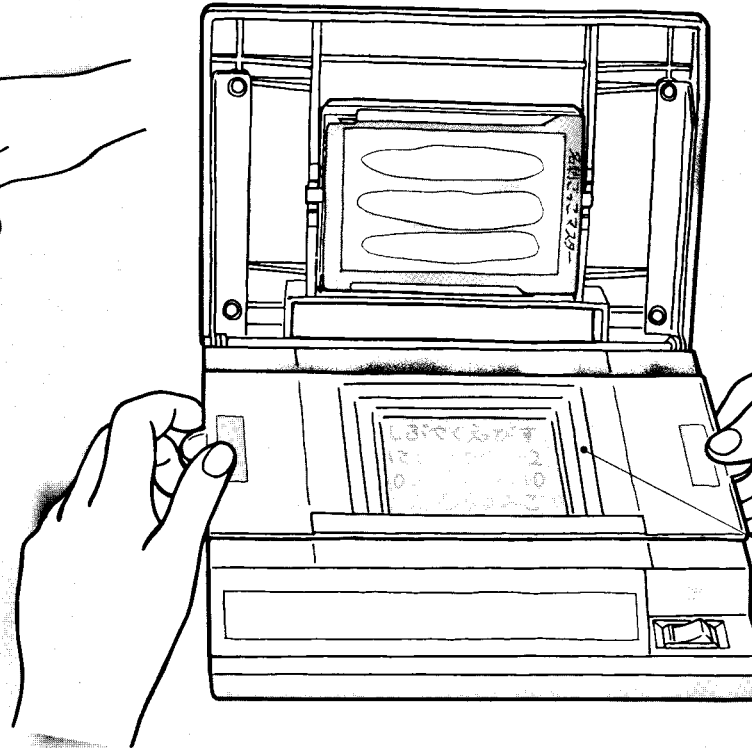

Groove (business card holding seat) in the printing frame.

Guidelines

**⑤ Fit a business card into the groove of the printing frame using the guidelines for correct positioning.**

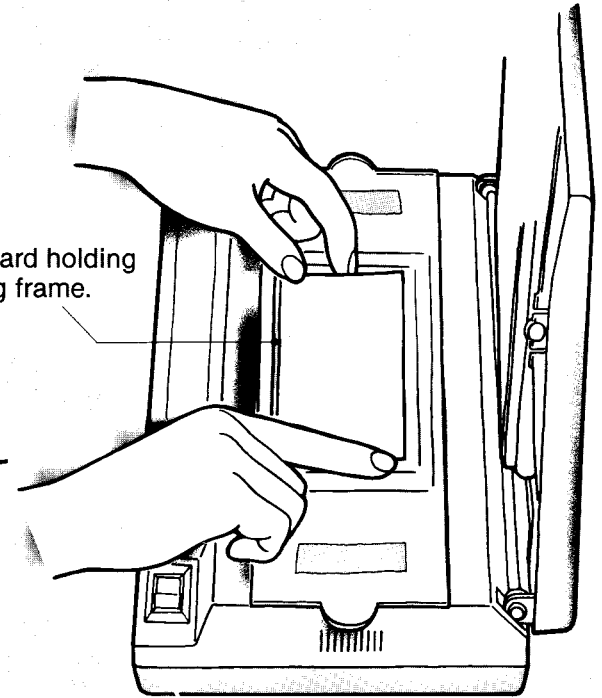

**If the print is smeared:**

Probable causes	Measures
The original was stained.	•Retouch with a white correction fluid, or make a new original.
Paper edges have imaged onto the Master.	•Brush off the mark on the Master with the OK Correction Fluid (blue) (optional), or cover with Scotch tape.
Dust on the Master.	
Pencil dust on original is causing spotting.	•Use a white correction fluid to hide stains, or make a new original.

**Dirty Print**

Some originals are dirty although in many instances you cannot see this. If the dirty original is used then the print result will be dirty. To eliminate these marks from your prints, use OK Correction fluid. In the case of a photo-copy, use the Blue Print Filter (optional).

⑥ Press down on the pressure lid to print the card.

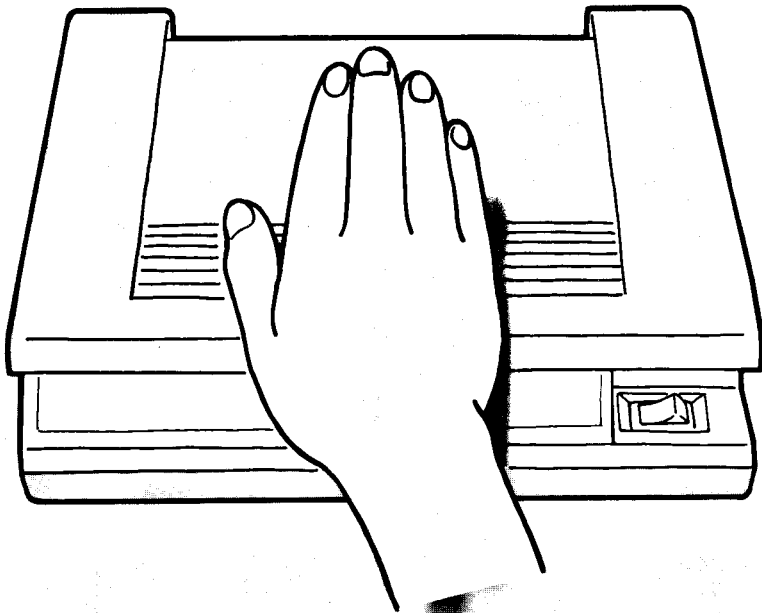

• Repeat steps ⑤ to ⑥ for required quantity of prints.

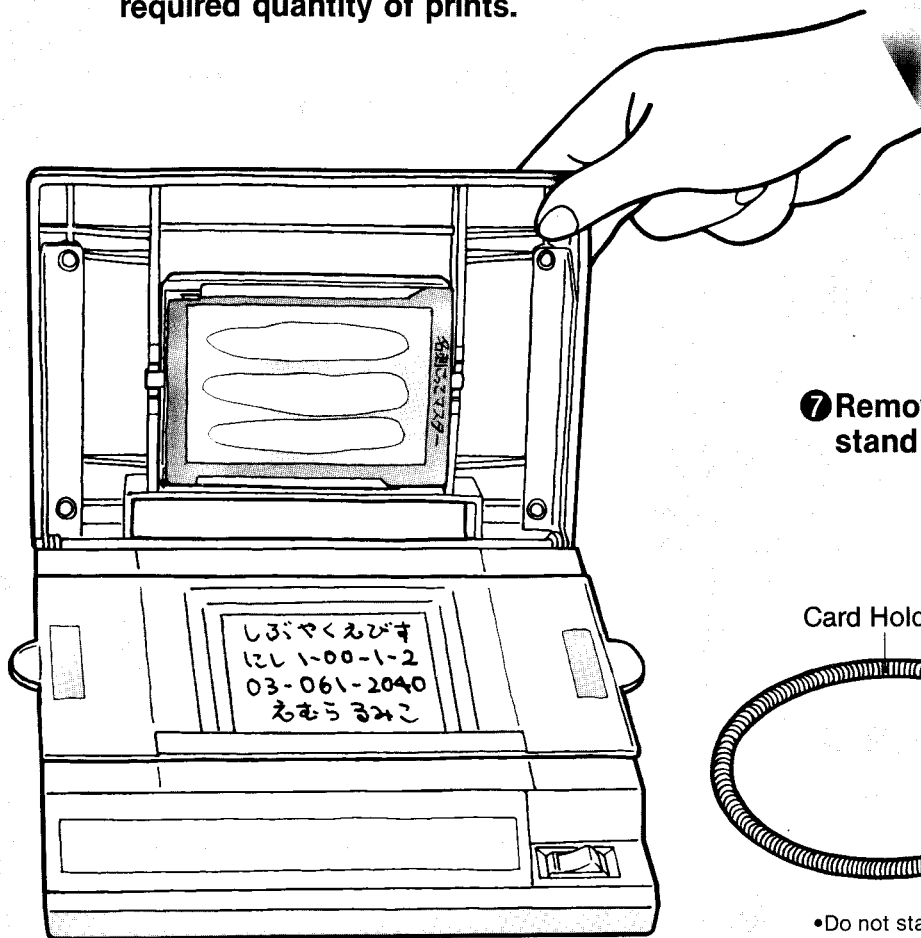

⑦ Remove the printed card, and stand it in the card holder to dry.

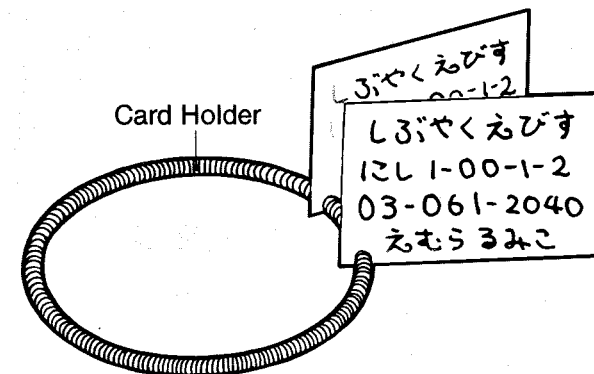

• Do not stack the cards.  
Dry them for 20 or 30 minutes.

If the print is hazy:

Probable causes	Measures
The original is still damp.	•Original must be dry before imaging. Dry with a hair dryer.
Glossy paper was used as an original.	•Make a new original with bond paper, or photocopy original.
The lettering or artwork on the original was indented.	•Rub the depressed part from behind to make flat. Or spray the depressed part with water to dampen it and iron out the depressed area. •Make a new original using a hard underlay, or photocopy original.
Lettering and artwork were drawn faintly and are illegible.	•Trace over defective lines using a carbon-containing writing instrument.
Ink running out.	•Turn over the transparent sheet and add ink.
Not enough pressure on the pressure lid.	•Press the pressure lid firmly and evenly.

If the print is not clear

When imaging the Master from an original printed by either typographic or letterpress printing, it is possible that there are sections of the original which are indented as a result of the printing method used. This is particularly the case with business name cards. If this is the case then rub the indented part from behind to make flat. If this is not successful, use a photo-copy making sure that you place a solid backing sheet behind original to hold it firm against the glass top of the photo-copier when making your copy.

•The MG MASTER may be left with ink applied. Remove the Master, and seal it in a plastic bag. It will remain re-useable for several days.

Drying ink

After printing, the ink penetrates the paper and dries. When printing or stamping on paper which is difficult to penetrate (art paper, coated paper, etc.), the drying time of the ink will be longer. Leave the printed copies sufficiently long enough for the ink to dry before moving them.

# COLORFUL STAMPING

YOUR RISO MG-11

TURNS INTO A COLORFUL STAMP.

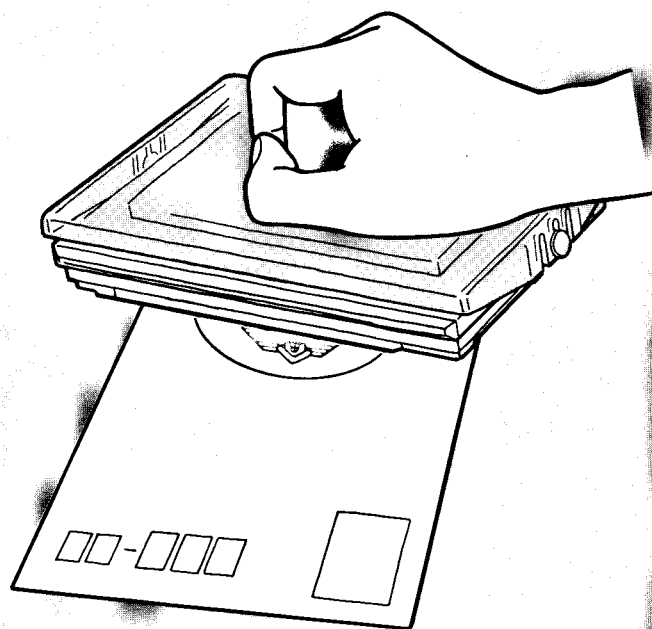

Use the MG Stamp provided with the set to stamp your message, symbol or slogan on post cards, etc.

Ex. 1: Logo for letters, post cards, envelopes, etc.

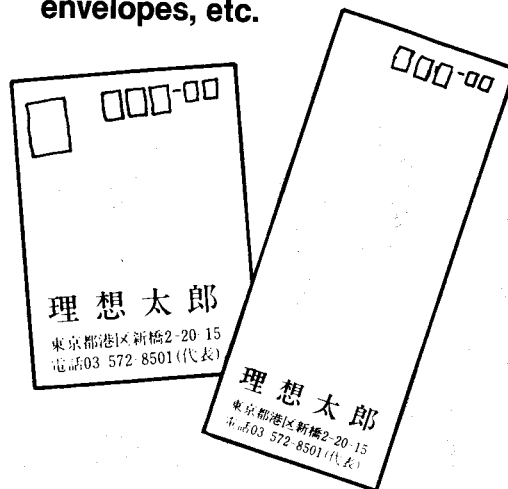

Ex. 3: Corporate name and name of representative in charge of catalogs, etc.



Ex. 2: Family emblem used for a letterhead, etc.

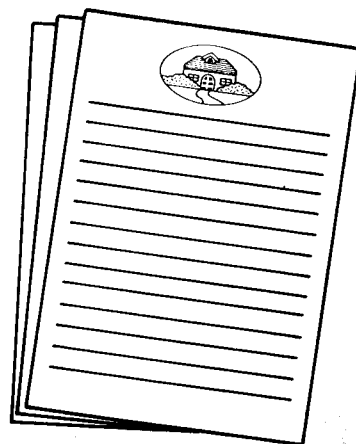

Ex. 4: Patterns for hand-made wrapping paper.

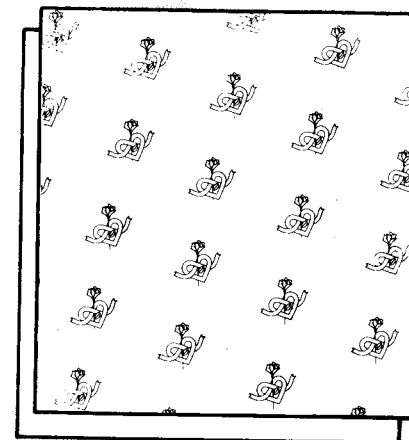

Now you are a graphic artist. Enjoy!

# HOW TO USE THE MG STAMP

## Preparing an original artwork

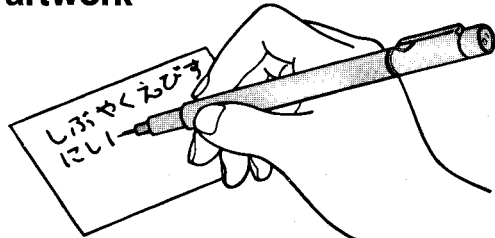

(pages 4 and 5)



## Imaging the MG Master

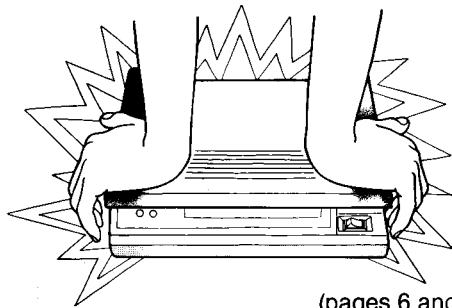

(pages 6 and 7)



## Applying the Ink

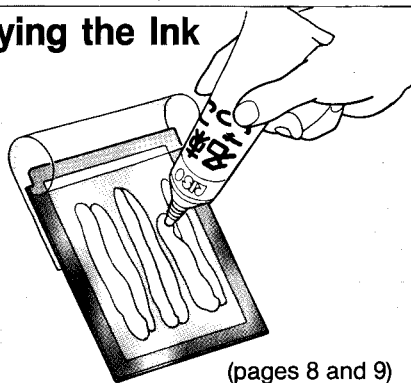

(pages 8 and 9)

•The same as the printing process up to this point.

- Remove the pad table from the main unit, and set the inked Master into the Master holder on the printing side of the pad table.

•Be sure to set the Master so that the corners line up with those of the Master holder.

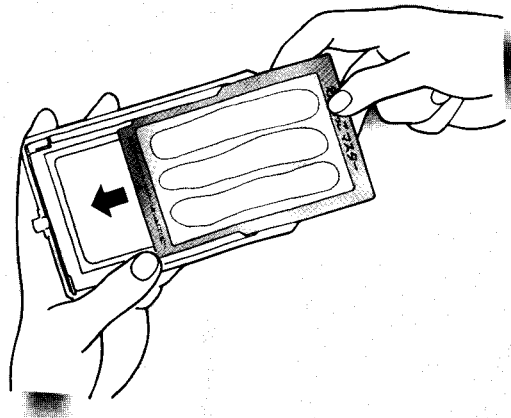
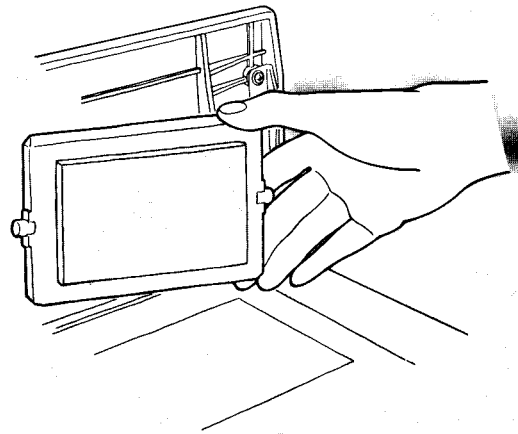

- With the Master facing outwards, insert the Pad table into the MG Stamp.

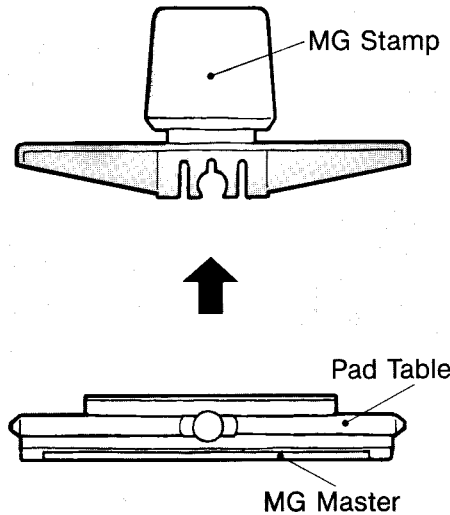

- Hold the handle grip of the Stamp and use in the same manner as you would use a rubber stamp.

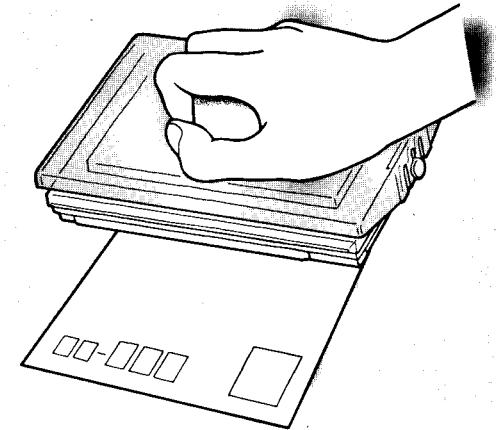

Position correctly and press firmly to achieve the best results. Lift the Stamp directly off the print and do not tilt as lifting otherwise smudging may occur.

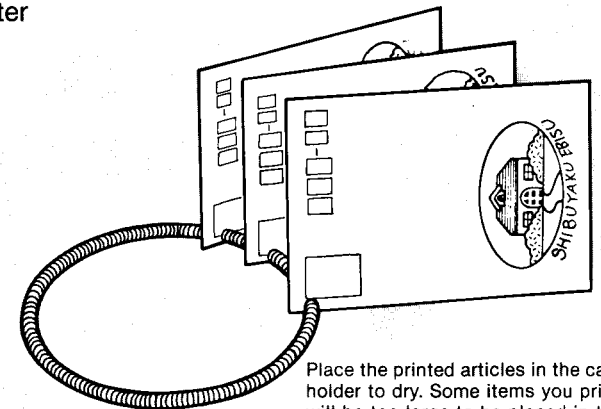

Place the printed articles in the card holder to dry. Some items you print will be too large to be placed in the card holder. Lay them flat for about ten minutes to ensure that they are dry before handling them.

# IMAGING MASTERS FOR PRINT GOCCO B6.

If you have a PRINT GOCCO B6, you can image the Print Gocco B6 Masters on your RISO MG-11 and therefore eliminate the need for the use of Print Lamps.

Imaging the Print Gocco B6 Masters is a simple three step process outlined as follows.

- 1 Place the Print Gocco B6 Master onto the stage, with the transparent cover sheet facing down. Position your artwork face down on top of the Print Gocco B6 Master. Place the center line of the Print Gocco B6 Master in alignment with the front register marks ►◄ on the stage of the RISO MG-11 and press down the pressure lid until the unit flashes.

•Wait about 10 seconds to recharge between flashes.  
When the OK light comes on, you are ready for the next flash.

- 2 Move the Master through until the center line is in alignment with the center register marks ►◄ on the stage. Check to see that the OK light is on and flash the unit once more.

- 3 Move the Master through again until the center line is in alignment with the back register marks ►◄ on the stage. Check the OK light and flash the unit a third time.

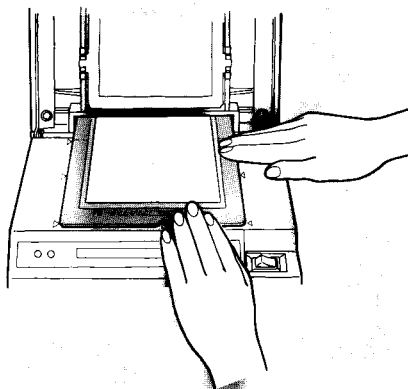
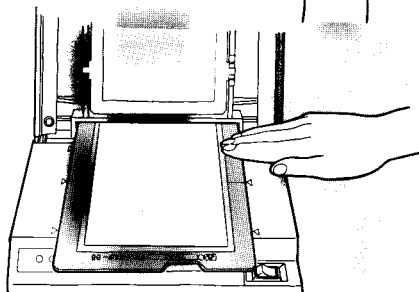
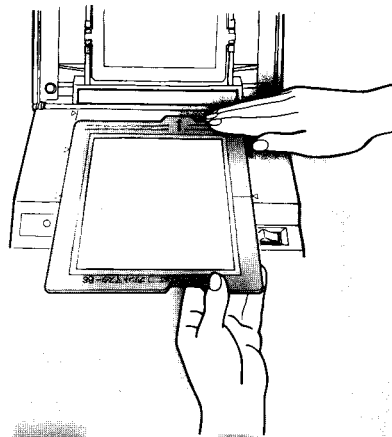

The Print Gocco B6 Master is now imaged and ready for inking and printing on your Print Gocco B6.

## APPLICATIONS

By now we are sure that you will have thought of many applications and uses for your RISO MG-11. Here are some more that you may wish to use.

1. Business cards.
2. Letterheads.
3. Envelopes.
4. Overprinting on catalogue sheets.
5. Overprinting stationery.
6. Wall paper designs.
7. Printing directly into books.
8. Printing onto signs and posters.
9. Report covers
10. Memos and call back forms.
11. Overprinting price lists.
12. Coupons and raffle tickets.
13. Promotional announcements.
14. Postcards.
15. Carton stamping.
16. Announcements.
17. Invitations.
18. Greeting cards.
19. Party items.
20. Menu specials

This list is to give you some ideas to think about. From here on it is up to your imagination.

We are sure that you will find many good and valuable ideas for your RISO MG-11.